

# KT500 Tunnel

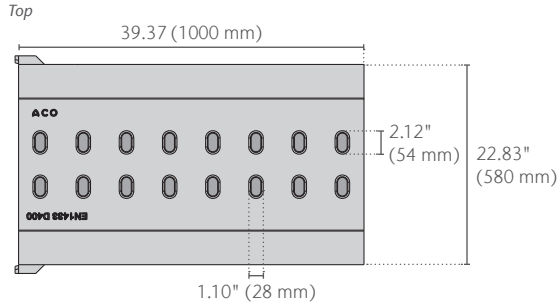

## Fence



## Front

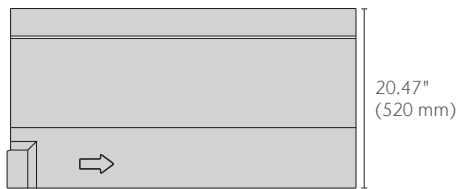

## Side

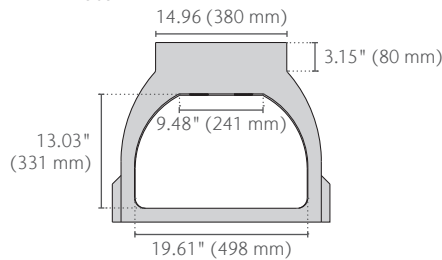

Parts	Part No.	Length in (mm)	Width in (mm)	Weight lbs
KT500 Tunnel	<b>11120</b>	39.37 (1000)	24.80 (630)	567.0

## Specification Summary

### General

The tunnel and fencing system shall be ACO Wildlife KT500 Tunnel, Fence and Entrance as manufactured by ACO, Inc. ACO Climate Tunnel and ACO PRO Amphibian Wall also support KT500 Tunnel.

### Fencing

Fencing shall be specified. See separate ACO Spec Info sheets for details.

### Installation

The tunnel and fencing system shall be installed in accordance with the manufacturer's installation instructions and recommendations.

### Materials

The trench system bodies shall be manufactured from polymer concrete with the minimum properties as follows:

- Compressive strength: 13,053 psi
- Flexural strength: 3,191 psi
- Water absorption rate: 0.07%
- Resistant to dilute acid and alkali
- Frost-proof
- Salt-proof

## ACO, Inc.

© January 2026 ACO, Inc.

All reasonable care has been taken in compiling the information in this document. All recommendations and suggestions on the use of ACO products are made without guarantee since the conditions of use are beyond the control of the company. It is the customer's responsibility to ensure that each product is fit for its intended purpose and that the actual conditions of use are suitable. ACO, Inc. reserves the right to change products and specifications without notice.

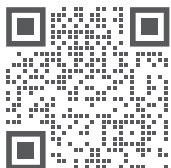

info@acousa.com  
www.acousa.com

